

BIDDING FORMS

(Must be completed by all bidders)

**BID SCHEDULE FORM
STIPULATED PRICE-LUMP SUM AND UNIT PRICE**

DATE OF ISSUANCE: August 31, 2021

ENGINEER'S PROJECT NO: 121077

Proposal of Caldwell Tanks, Inc. ("BIDDER"), organized and existing under the laws of the State of Kentucky doing business as a Corporation *.

To the **MADISON COUNTY COMMISSIONERS ("OWNER")**, located at **1 N MAIN STREET, LONDON, OHIO 43140.**

In compliance with your Invitation to Bids, BIDDER hereby proposes to perform all WORK for the construction of Project known as **MADISON COUNTY WATER SYSTEM – ELEVATED WATER STORAGE TANK** in strict accordance with the CONTRACT DOCUMENTS, within the time set forth therein, and at the prices set forth on this Bid Schedule Form.

BIDDER submits this Bid Security, Qualifications and Resources of Bidder and Experience Statement of Bidder. By submission of this BID, each BIDDER certifies, and in the case of a joint BID each party thereto certifies as to its own organization, that this BID has been arrived at independently, without consultation, communication, or agreement as to any matter relating to this BID with any other BIDDER or with any competitor the Non-Collusion Affidavit is attached. BIDDER CONTRACTOR also submits the Delinquent Personal Property Tax Affidavit.

BIDDER hereby agrees to commence WORK under this Contract on or before a date to be specified in the NOTICE TO PROCEED, be **Substantially Complete within 365 consecutive calendar days** after the date when the Contract Times commence to run as provided in Paragraph 2.03 of the General Conditions to the Contract and to **fully complete the PROJECT within 395 consecutive calendar days** after the date the Contract Time commences to run. BIDDER further agrees to pay as liquidated damages, the sum of **\$900.00** per day for each consecutive calendar day as provided in Article 4.03 of the Contract between Owner and Contractor.

BIDDER acknowledges receipt of the following ADDENDA

Addendum No: 1 Date: August 18, 2021

Addendum No: 2 Date: August 20, 2021

Addendum No: 3 Date: August 25, 2021

BIDDER agrees to perform all the Work for the Bid and Alternates as described in the CONTRACT DOCUMENTS for the following lump sum prices:

* Insert "a corporation", "a partnership", or "an individual" as applicable.

BID SCHEDULE FORM
MADISON COUNTY WATER SYSTEM – ELEVATED WATER STORAGE TANK

DATE OF ISSUANCE: August 31, 2021

ENGINEER'S PROJECT NO: 121077

BIDDER agrees to perform all Work described in the Contract Documents for the following Bid and Alternates on a lump sum and unit price basis. OWNER is exempt from Ohio State sales tax. BIDS shall include all other applicable taxes and fees. Liquidated Damages are provided in the Contract in Article 4.03.

ITEM	DESCRIPTION	QTY.	UNIT	UNIT COSTS			TOTAL COST OF ITEM
				LABOR	MATERIALS	TOTAL	
1	Elevated Storage Tank	EA	1	\$540,000.00	\$1,028,882.50	\$1,568,882.50	\$1,568,882.50
2	16" DI Water Line	LF	138	\$152.00	\$50.00	\$202.00	\$27,876.00
3	16" Check Valve and Vault	EA	2	\$14,000.00	\$600.00	\$14,600.00	\$29,200.00
4	Concrete pad for Building	SY	36	\$350.00	\$150.00	\$500.00	\$18,055.50
5	Chlorination Station (At Tank)	EA	1	\$270,000.00	\$26,000.00	\$296,000.00	\$296,000.00
6	4" DI Pipe	LF	70	\$116.00	\$46.00	\$162.00	\$11,340.00
7	Gravel Drive, O.D.O.T Item 304	CY	90	\$100.00	\$35.00	\$135.00	\$12,150.00
8	Electrical to Building	LS	1	\$4,500.00	\$10,250.00	\$14,750.00	\$14,750.00
9	Electrical to Tank	LS	1	\$3,850.00	\$16,100.00	\$19,950.00	\$19,950.00
10	Tank Lighting	LS	1	\$6,500.00	\$26,200.00	\$32,700.00	\$32,700.00
11	Seeding/mulching	LS	1	\$1,000.00	\$3,500.00	\$4,500.00	\$4,500.00
12	16"x16"x16" Tee into Main	EA	2	\$3,000.00	\$2,418.00	\$5,418.00	\$10,836.00
13	Fire Hydrant and Watch Valve	EA	2	\$5,465.00	\$2,000.00	\$7,465.00	\$14,930.00
14	6" PVC Water Line to Hydrant	LF	7	\$85.00	\$35.00	\$120.00	\$840.00
15	Chain Link Fence	LF	350	\$75.00	\$18.00	\$93.00	\$32,550.00
16	Gate for Fence	EA	1	\$1,500.00	\$500.00	\$2,000.00	\$2,000.00
17	Rock channel Protection	CY	6	\$100.00	\$35.00	\$135.00	\$810.00
18	12" Storm Culvert	LF	20	\$50.00	\$24.00	\$74.00	\$1,480.00
19	Site Grading	LS	1	\$1,000.00	\$5,750.00	\$6,750.00	\$6,750.00
TOTAL							\$2,105,600.00
TOTAL WRITTEN IN WORDS:				Two Million One Hundred Five Thousand Six Hundred Dollars			

Total Bid amount and individual item prices shall be guaranteed for up to ninety (90) consecutive calendar days after date of Bid Opening.

Respectfully submitted: *Attach appropriate evidence to show authority to sign and do business (See Instructions to Bidders).

[Signature]
 Signature of BIDDER/CONTRACTOR*

Kevin J. Gallagher, PE, Vice President
 Title

Caldwell Tanks, Inc.
 Name of BIDDER/CONTRACTOR (Type or Print in ink)

August 31, 2021
 Date

4000 Tower Road
 Address

(502) 964-3361 (502) 966-8732
 Telephone Number Fax Number

Louisville, Kentucky 40219
 City State Zip Code

sales@caldwelltanks.com
 E-Mail

SEAL - (if BID is by a corporation)
[Signature]
 Attest: David E. Bartley, Secretary

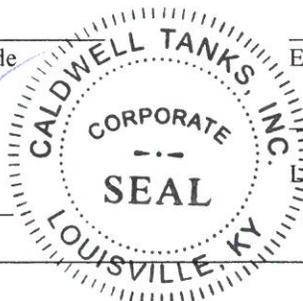

License Number (if applicable) N/A for Ohio

BID GUARANTY, CONTRACT AND PERFORMANCE BOND

KNOW ALL MEN BY THESE PRESENTS, that we, the undersigned Caldwell Tanks, Inc. as Principal (BIDDER/CONTRACTOR) and Great American Insurance Company as Sureties, are hereby held and firmly bound unto Madison County Commissioners OWNER, as obligee, in the penal sum of the dollar amount of the Bid submitted by the Principal (BIDDER/CONTRACTOR) to the OWNER, as obligee, on August 31, 20 21 (insert date) to undertake the project known as Contract 4: Elevated Water Storage Tank (the "Project"). The penal sum referred to herein shall be the dollar amount of the Principal (BIDDER/CONTRACTOR)'s Bid to the OWNER, incorporating any additive or deductive alternate Bids made by the Principal (BIDDER/CONTRACTOR) on the date referred to above to the OWNER, which are accepted by the OWNER. In no case shall the penal sum exceed the amount of _____ dollars. (If the foregoing blank is not filled in, the amount stated must not be less than the full amount of the bid including alternates, in dollars and cents. A percentage is not acceptable.) For the payment of the penal sum well and truly to be made, we hereby jointly and severally bind ourselves, our heirs, executors, administrators, successors, and assigns.

Signed this 31st day of August 20 21. THE CONDITION OF THE ABOVE OBLIGATION IS SUCH, that whereas the above named Principal (BIDDER/CONTRACTOR) has submitted a bid for Madison County Water System.

Contract 4: Elevated Water Storage Tank

NOW, THEREFORE, if the OWNER accepts the Bid of the Principal (BIDDER/CONTRACTOR) and the Principal (BIDDER/CONTRACTOR) fails to enter into a proper Contract in accordance with the Bid, Plans, details, Specifications, and bills of material; and in the event the Principal (BIDDER/CONTRACTOR) pays to the OWNER the difference not to exceed ten (10) percent of the penalty hereof between the amount specified in the Bid and such larger amount for which the OWNER may in good faith contract with the next lowest Bidder to perform the Work covered by the Bid; or in the event the OWNER does not award the Contract to the next lowest Bidder and resubmits the Project for bidding, the Principal (BIDDER/CONTRACTOR) pays to the OWNER the difference not to exceed ten (10) per cent of the penalty hereof between the amount specified in the Bid, or the costs, in connection with the resubmission, of printing new Contract Documents, required advertising, and printing and mailing notices to prospective Bidders, whichever is less, then this obligation shall be null and void, otherwise to remain in full force and effect; if the OWNER accepts the bid of the Principal (BIDDER/CONTRACTOR) and the Principal (BIDDER/CONTRACTOR) within ten (10) days after the awarding of the Contract enters into a proper Contract in accordance with the Bid, Plans, details, Specifications, and bills of material, which said Contract is made a part of this Bond the same as though set forth herein;

NOW, ALSO, if the said Caldwell Tanks, Inc. Principal (BIDDER/CONTRACTOR) shall well and faithfully do and perform each and every term and condition of the Contract, indemnify the OWNER against any and all damages suffered by failure to perform such Contract according to the provisions thereof and in accordance with the Plans, details, Specifications, and bills of material therefor; shall pay all lawful claims of subcontractors, materials suppliers, and laborers, for labor performed and materials furnished in the carrying forward, performing, or completing of said Contract and after one year from the Date of Final Completion; we agreeing and assenting that this undertaking shall be for the benefit of any materials suppliers or laborer having a just claim, as well as for the OWNER as obligee herein; then this obligation shall be void; otherwise the same shall remain in full force and effect; it being expressly understood and agreed that the liability of the surety for any and all claims hereunder shall in no event exceed the penal amount of this obligation as herein stated.

The said Surety hereby stipulates and agrees that no modifications, omissions, or additions, in or to the terms of the said Contract or in or to the Plans or Specifications therefor shall in any way affect the obligations of said Surety on its Bond and it does hereby waives notice of any such modifications, omissions, or additions to the terms of the Contract, Work, Plans or Specifications.

IN WITNESS WHEREOF, this instrument is executed in 1 (number) counterparts, each one of which shall be deemed an original, this the 31st day of August 20 21.

Principal (BIDDER/CONTRACTOR): Caldwell Tanks, Inc.

David E. Bartley
Witness as to Principal (BIDDER/CONTRACTOR)
David E. Bartley, Secretary

By: *Kevin J. Gallagher*
Name: Kevin J. Gallagher PE
Title: Vice President



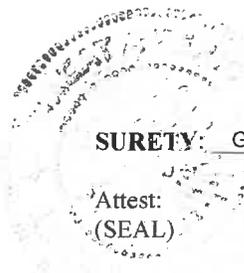

SURETY: Great American Insurance Company

Attest:
(SEAL)

[Handwritten Signature]

Witness as to Surety

By: *Cherie Brewer*
Attorney-in-Fact Cherie Brewer

SURETY COMPANY ADDRESS:

301 East Fourth Street
Street

Cincinnati, Ohio 45202
City State Zip

513-412-9176
Telephone

SURETY AGENT'S ADDRESS:

Sterling Thompson Insurance
Agency Name

3006 Eastpoint Parkway
Street

Louisville, Kentucky 40223
City State Zip

502-585-3277
Telephone

INSTRUCTIONS:

(Ohio Revised Code Section 153.57.1 (combination form) to be used when BIDDER selects 153.54A1-Bid Bond)

Date of Bond must not be prior to date of Contract. (If PRINCIPAL is Partnership, all partners shall execute Bond.)

IMPORTANT: Surety companies executing Bonds must appear on the Treasury Department's most current list (Circular 570 as amended) and must not exceed the underwriting limitation.

Surety companies must be authorized to transact business in the state of Ohio and shall furnish proof of such authorization with the Bid.

GREAT AMERICAN INSURANCE COMPANY®

Administrative Office: 301 E 4TH STREET • CINCINNATI, OHIO 45202 • 513-369-5000 • FAX 513-723-2740

The number of persons authorized by this power of attorney is not more than FIVE

No. 0 21502

POWER OF ATTORNEY

KNOW ALL MEN BY THESE PRESENTS: That the GREAT AMERICAN INSURANCE COMPANY, a corporation organized and existing under and by virtue of the laws of the State of Ohio, does hereby nominate, constitute and appoint the person or persons named below, each individually if more than one is named, its true and lawful attorney-in-fact, for it and in its name, place and stead to execute on behalf of the said Company, as surety, any and all bonds, undertakings and contracts of suretyship, or other written obligations in the nature thereof; provided that the liability of the said Company on any such bond, undertaking or contract of suretyship executed under this authority shall not exceed the limit stated below.

Name	Address	Limit of Power
PHILIP D. ANDERTON	ALL OF	ALL
BRIAN CRAWFORD	LOUISVILLE,	\$100,000,000
NED BOOKER	KENTUCKY	
CHERIE BREWER		
JOHN MARK STRADER		

This Power of Attorney revokes all previous powers issued on behalf of the attorney(s)-in-fact named above.

IN WITNESS WHEREOF the GREAT AMERICAN INSURANCE COMPANY has caused these presents to be signed and attested by its appropriate officers and its corporate seal hereunto affixed this 1ST day of FEBRUARY, 2021
GREAT AMERICAN INSURANCE COMPANY



Stephen C. Beraha
Assistant Secretary

Mark Vicario
Divisional Senior Vice President

STATE OF OHIO, COUNTY OF HAMILTON - ss:

On this 1ST day of FEBRUARY, 2021, before me personally appeared MARK VICARIO, to me known, being duly sworn, deposes and says that he resides in Cincinnati, Ohio, that he is a Divisional Senior Vice President of the Bond Division of Great American Insurance Company, the Company described in and which executed the above instrument; that he knows the seal of the said Company; that the seal affixed to the said instrument is such corporate seal; that it was so affixed by authority of his office under the By-Laws of said Company, and that he signed his name thereto by like authority.

MARK VICARIO (877-377-2405)



SUSAN A KOHORST
Notary Public
State of Ohio
My Comm. Expires
May 18, 2025

Susan A Kohorst

This Power of Attorney is granted by authority of the following resolutions adopted by the Board of Directors of Great American Insurance Company by unanimous written consent dated June 9, 2008.

RESOLVED: That the Divisional President, the several Divisional Senior Vice Presidents, Divisional Vice Presidents and Divisional Assistant Vice Presidents, or any one of them, be and hereby is authorized, from time to time, to appoint one or more Attorneys-in-Fact to execute on behalf of the Company, as surety, any and all bonds, undertakings and contracts of suretyship, or other written obligations in the nature thereof; to prescribe their respective duties and the respective limits of their authority; and to revoke any such appointment at any time.

RESOLVED FURTHER: That the Company seal and the signature of any of the aforesaid officers and any Secretary or Assistant Secretary of the Company may be affixed by facsimile to any power of attorney or certificate of either given for the execution of any bond, undertaking, contract of suretyship, or other written obligation in the nature thereof, such signature and seal when so used being hereby adopted by the Company as the original signature of such officer and the original seal of the Company, to be valid and binding upon the Company with the same force and effect as though manually affixed.

CERTIFICATION

I, STEPHEN C. BERAHA, Assistant Secretary of Great American Insurance Company, do hereby certify that the foregoing Power of Attorney and the Resolutions of the Board of Directors of June 9, 2008 have not been revoked and are now in full force and effect.

Signed and sealed this 31st day of August, 2021

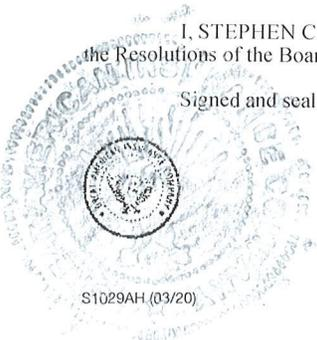

Stephen C. Beraha
Assistant Secretary



IBI GROUP
 8101 North High Street, Suite 100
 Columbus OH 43235 USA
 tel 614 818 4900 fax 614 818 4901
 ibigroup.com

**MADISON COUNTY WATER SYSTEM
 ELEVATED WATER STORAGE TANK**

**ADDENDUM #1
 August 18, 2021**

This addendum covers modifications to the Documents and shall become a part of the Documents for this project.

The following documents have been added to the specifications and/or revised for the aforementioned project:

1. 00 45 13 Qualifications and Resources of Bidder
2. 09 97 13 Steel Coating New Water Tank Painting
3. 26 09 23 Lighting Control Devices
4. 26 28 16 Enclosed Switches and Circuit Breakers
5. 26 29 13 Enclosed Controllers
6. 33 16 19 Pedesphere Elevated Water Storage Tank

The following are clarifications and/or revisions to the original specifications and plans:

If you have any questions regarding this addendum, please address in writing to IBI Group, in care of Kevin Wood, P.E. (kevin.wood@ibigroup.com) or Maria Borchers (maria.borchers@ibigroup.com)

Each contractor submitting a bid shall sign and date this addendum and include it with the bid package.

Caldwell Tanks, Inc.
 Name/Company _____
 Kevin J. Gallagher, PE
 Vice President

August 31, 2021
 Date _____

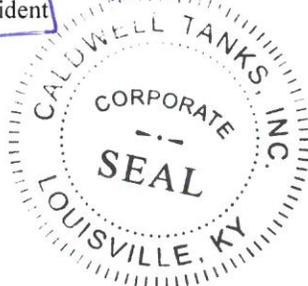



IBI GROUP
 8101 North High Street, Suite 100
 Columbus OH 43235 USA
 tel 614 818 4900 fax 614 818 4901
 ibigroup.com

**MADISON COUNTY WATER SYSTEM
 ELEVATED WATER STORAGE TANK**

**ADDENDUM #2
 August 20, 2021**

This addendum covers modifications to the Documents and shall become a part of the Documents for this project.

The following documents have been added to the specifications and/or revised for the aforementioned project:

1. 00 43 33 Proposed Equipment List
 - a. Alternate materials: Ductile Iron Class 350 & Fusible PVC C90
2. Davis-Bacon Federal Ware Rates

The following are clarifications and/or revisions to the original specifications and plans:

1. The Bidders shall provide copies of pipe and fittings or steel material quotes signed by the supplier utilized for the preparation of their bid. A change order will be issued at the time of Contract Award for demonstrated increases or decreases in material cost. The Bidder is fully responsible for proposing manufacturers, which conform to the project requirements as set forth in the Contract Documents. Should the Bidder not provide copies of the material quotes with their bid, they will automatically waive their right to receive a contract adjustment for changes in material costs at the time of Contract Award.

If you have any questions regarding this addendum, please address in writing to IBI Group, in care of Kevin Wood, P.E. (kevin.wood@ibigroup.com) or Maria Borchers (maria.borchers@ibigroup.com)

Each contractor submitting a bid shall sign and date this addendum and include it with the bid package.

Caldwell Tanks, Inc.
 Name/Company

Kevin J. Gallagher, PE, Vice President



August 31, 2021

Date



IBI GROUP
 8101 North High Street, Suite 100
 Columbus OH 43235 USA
 tel 614 818 4900 fax 614 818 4901
 ibigroup.com

**MADISON COUNTY WATER SYSTEM
 ELEVATED WATER STORAGE TANK**

**ADDENDUM #3
 August 25, 2021**

This addendum covers modifications to the Documents and shall become a part of the Documents for this project.

The following documents have been added to the specifications and/or revised for the aforementioned project:

1. 09 97 13 Steel Coatings New Water Tank Painting
 - a. Section 3.6 Lettering

The following are clarifications and/or revisions to the original specifications and plans:

1. The Engineer's Estimate for Contact 4 has increased to \$2,000,000.
2. The 12" Drive Culvert shall be Concrete
3. 3 Inches of Fiberglass insulation with ASJ Jacket and SSL Max Closure System shall be installed around the exposed piping inside the riser pipe.
4. In Spec 33 14 43 Packaged Water Tank Recirculation Pump Station, George Young's phone number is 859-640-6186
5. Unless specifically noted, Work shall have a one-year warranty.

If you have any questions regarding this addendum, please address in writing to IBI Group, in care of Kevin Wood, P.E. (kevin.wood@ibigroup.com) or Maria Borchers (maria.borchers@ibigroup.com)

Each contractor submitting a bid shall sign and date this addendum and include it with the bid package.

Caldwell Tanks, Inc.
 Name/Company

Kevin J. Gallagher, PE, Vice President

August 31, 2021
 Date



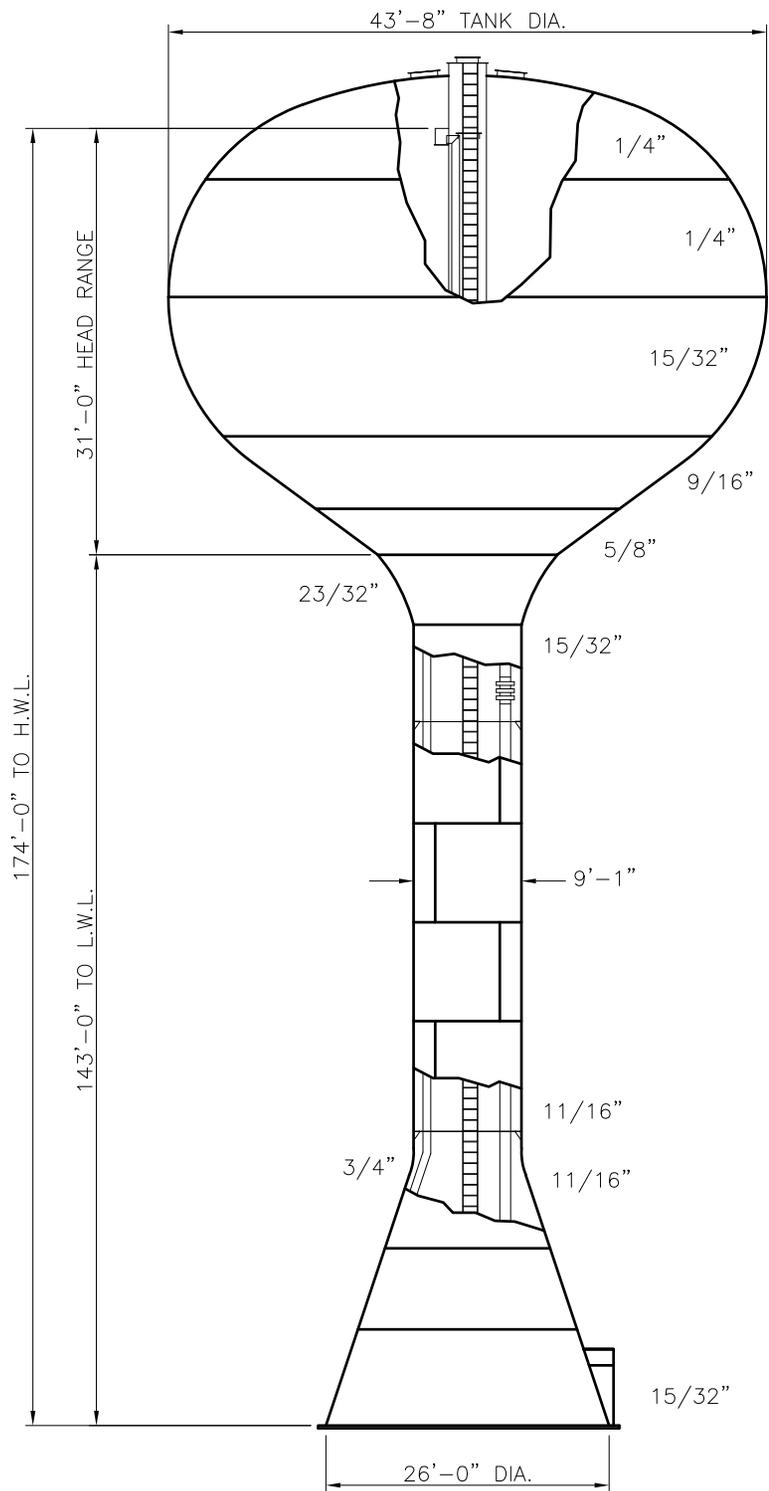

NOTE:

DESIGN PER AWWA D100-11 AND ENGINEER'S SPECIFICATIONS.

ALL ACCESSORIES TO BE INCLUDED AS PER SPECIFICATIONS.

ORIENTATION OF ACCESSORIES SHOWN FOR CLARITY.

SUBJECT TO CHANGE WITH FINAL DESIGN.

BASIC WIND SPEED: 90 MPH
 SEISMIC LOAD: $S_S = 16.4\%$ $S_1 = 6.2\%$
 25 PSF SNOW LOADING

 Since 1887 Water · Energy · Industrial	
MADISON COUNTY, OH 250,000 GALLON PEDESHERE	
BY: ADB	TITLE: TANK SKETCH
DATE: 8/27/21	DRAWING NO.: BID 143

NOTES:

FOUNDATION DESIGN BASED ON A NET ALLOWABLE SOIL BEARING OF 4,000 PSF.

CONCRETE: 28 DAY COMPRESSIVE STRENGTH OF 4,000 PSI. (74 CU. YDS.)

REINFORCEMENT: ASTM SPEC. A615 GR. 60. (9,200 LBS.)

REINFORCING STEEL QUANTITIES DO NOT ACCOUNT FOR LAPS, BENDS, HOOKS, ETC.

FOUNDATION IS SUBJECT TO CHANGE WITH FINAL DESIGN.

PIPING PIT NOT SHOWN.

SUBGRADE PREPARATION AND BACKFILL PER PROJECT GEOTECHNICAL REPORT AND SPECIFICATIONS.

FLOOR, PIPING PIT AND MISCELLANEOUS ACCESSORIES ARE NOT INCLUDED IN QUANTITIES SHOWN ABOVE.

THE PROJECT GEOTECHNICAL ENGINEER SHALL INSPECT AND APPROVE THE SUBGRADE PRIOR TO PLACEMENT OF STEEL OR CONCRETE.

WATER OBSERVED AT 8'-0" BELOW EXISTING GRADE. DEWATERING WILL BE REQUIRED.

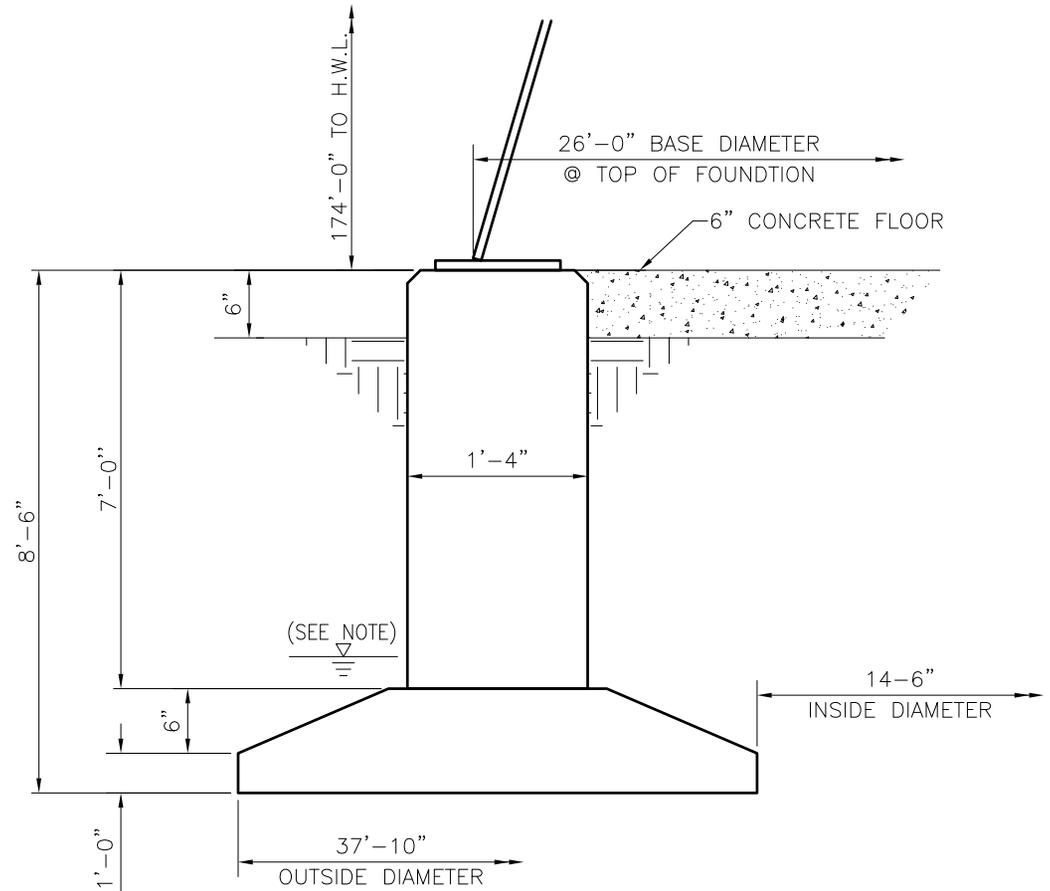

 Since 1887 <i>Water · Energy · Industrial</i>	
MADISON COUNTY, OH 250,000 GALLON PEDESHERE	
BY: ADB	TITLE: FOUNDATION SKETCH
DATE: 8/27/21	DRAWING NO.: BID 143